

Gasoline Engine Tachometers

SE-2500

For gasoline engine measurement applications

HT-6100

External sensor input type

For gasoline/diesel engines and general rotating objects



SE-2500



HT-6100

ONO SOKKI

SE-2500

Gasoline Engine Tachometer

For gasoline engine measurement applications

- 1 Built-in memory function**
20 data (MAX) can be saved to memory.
- 2 Three outputs— analog, monitor and pulse— provided as standard**
Use the analog output function to record the number of rotations, the monitor output function to check the sensor's detection waveform, and the pulse output function to output rotation synchronization signals.
- 3 Large LCD with backlight**
(Character height: 10.2 mm)
- 4 Capable of performing measurement at a distance of 1 m when the external sensor (IP-2800) is used.**
- 5 Can be mounted on a tripod**
The tachometer can be fixed to a tripod for continuous measurement.
- 6 Measurement can be performed in 1 r/min or 0.01 r/s units.**



Measurement method

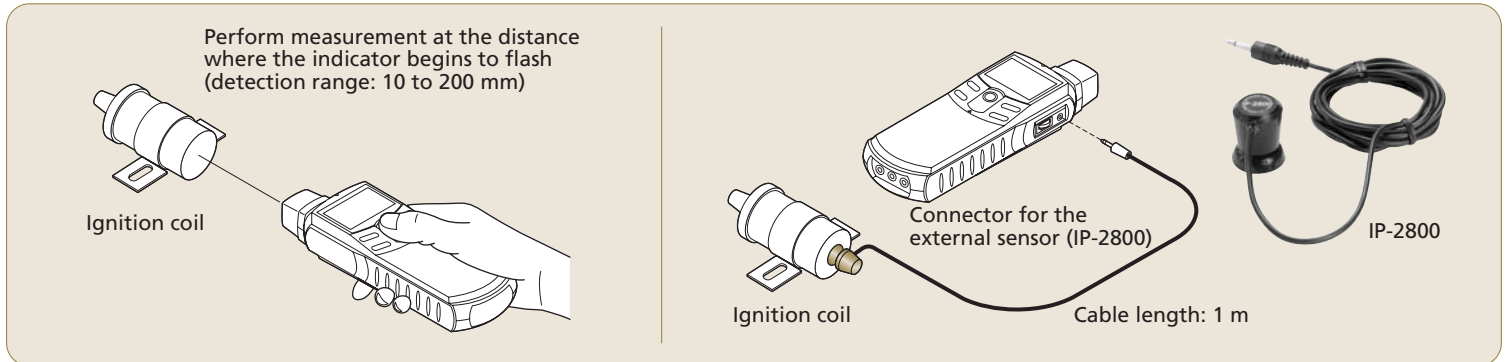

Specifications			
Applicable engines	Gasoline engines, 2-cycle (1, 2, 3, 4 cylinders); 4-cycle (1, 2, 3, 4, 5, 6, 7, 8, 10, 12 cylinders)		
Detection method	Electromagnetic induction		
Detection distance	10 to 200 mm		
Object of measurement	Ignition coil		
Calculation method	Cycle calculation method		
Measurement time	Within 1 s + the time required for one cycle		
Display	5-digit LCD, with backlight (character height: 10.2 mm)		
Display update time	1 ±0.2 s		
Measurement units	r/min, r/s		
Measurement ranges	2-cycle	4-cycle	Number of rotations (r/min)
	—	1 cylinder	120 to 20000
	1 cylinder	2 cylinders	120 to 20000
	—	3 cylinders	120 to 20000
	2 cylinders	4 cylinders	120 to 20000
	—	5 cylinders	120 to 20000
	3 cylinders	6 cylinders	120 to 15000
	4 cylinders	8 cylinders	120 to 12000
	—	10 cylinders	120 to 10000
	—	12 cylinders	120 to 8000
(r/s is the numerical value obtained when the r/min measurement value is divided by 60)			
Measurement accuracy	Displayed value* × (±0.02%) ±1 count * The displayed value is the count value excluding figures after the decimal point.		
Measurement functions	Memory function	20 data (MAX)	
	Over-range function	The over-range alarm (ERROR mark) is displayed when the measured value exceeds the display range.	
	Rotation upper limit alarm function	The upper limit alarm (↑ mark) is displayed when the number of rotations exceeds the preset upper limit value.	
	Sensitivity adjustment function	A rotary dial at the right-hand side of the device is used to adjust the sensitivity.	

Output section	Description of output function	Output with respect to the displayed rotation values		
		Output voltage	0 to 1 V/0 to FS (FS is freely selectable)	
Analog output	Conversion method	10-bit D/A conversion		
	Linearity	±1%/FS		
	Output update time	Within 50 ms + the time required for 1 cycle		
	Temperature stability	±0.05%/FS/°C (span & zero)		
	Setting error	±0.5%/FS		
	Load resistance	At least 100 kΩ		
	Monitor output	Description of output function	Analog output for monitoring purposes after waveform reshaping of the sensor signal	
		Load resistance	At least 100 kΩ	
	Pulse output	Output voltage	Hi level: At least +4.5 V Lo level: Up to +0.5 V	
		Output logic	Positive logic	
Load resistance		At least 100 kΩ		
General specifications	Power source	Four AAA alkaline batteries or exclusive AC adapter (PB-7080, Option)		
	Battery life	At least 32 hours (when the backlight is OFF) At least 8 hours (when the backlight is ON)		
	Low battery alarm indicator	A low battery alarm (LOW mark) is displayed when the battery voltage falls below 4.4 V.		
	Operating temperature range	0 to 40°C		
	Storage temperature range	-10 to 50°C		
	Outer dimensions	198.5 (W) x 47.5 (H) x 66 (D) mm		
	Weight (including batteries)	Approx. 300 g		
	Accessories	Ignition detector (IP-2800)	1	
		AAA alkaline batteries	4	
		Carrying case	1	

HT-6100

Handheld Digital Tachometer

For the measurement of gasoline and diesel engines and of various rotating objects (external sensor input type)

- 1 Can be used with various sensors**
The HT-6100 can be used with the optional IP-292, IP-296, IP-3000 and OM-1200 detectors, as well as with TTL signal output detectors.
- 2 Three outputs— analog, monitor and pulse— provided as standard**
Use the analog output function to record the number of rotations, the monitor output function to check the sensor's detection waveform, and the pulse output function to output rotation synchronization signals.
- 3 Built-in peak hold function**
The maximum and minimum values can be displayed during measurement.
- 4 Large LCD with backlight**
(Character height: 10.2 mm)
- 5 Built-in memory function**
20 data (MAX) can be saved to memory.
- 6 Can be mounted on a tripod**
The tachometer can be fixed to a tripod for continuous measurement.



HT-6100

Measurement method

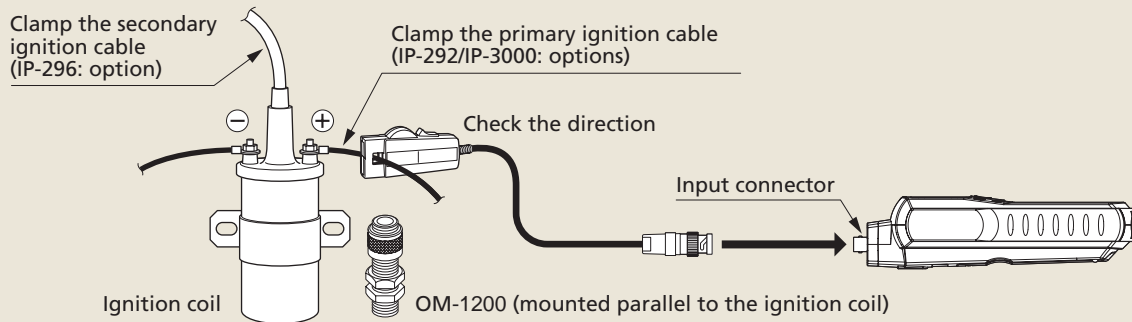









Specifications

Applicable engines	Gasoline and diesel engines; general rotating objects	
Compatible detectors	IP-292, IP-296, IP-3000, OM-1200, TTL signal output detectors	
Object of measurement	Ignition coil, primary/secondary ignition cables, ECU rotation pulses (5-V)	
Calculation method	Cycle calculation method	
Measurement time	Within 1 s + the time required for one cycle	
Display	5-digit LCD, with backlight (character height: 10.2 mm)	
Display update time	1 ±0.2 s	
Measurement units	r/min (when the IP-292, IP-296, IP-3000, or OM-1200 detector has been selected)	
	r/min, r/s, m/min, ms, COUNT (when a TTL signal output detector has been selected)	
Measurement ranges		IP-292, IP-296, IP-3000, OM-1200
		TTL signal output detector
	r/min	120 to 20000
	r/s	—
	m/min	—
Measurement accuracy	*The number of pulses per rotation (0.5 to 200.0 P/R) is freely selectable.	
	Displayed value * x (±0.02%) ±1 count	
	* The displayed value is the count value excluding figures after the decimal point. The measurement accuracy of the line speed depends on the rotational (r/min) accuracy.	
Measurement functions	Peak hold function	Maximum value (MAX), minimum value (MIN)
	Memory function	20 data (MAX)
	Over-range function	The over-range alarm (ERROR mark) is displayed when the measured value exceeds the display range.
	Rotation upper limit alarm function	The upper limit alarm (1 mark) is displayed when the number of rotations exceeds the preset upper limit value.
	Line speed calculation function	Calculates the line speed from the preset diameter value (mm) and the measured number of rotations
	Accumulating function	Provides a cumulative count of the input signal pulses
	Cycle measurement function	Measures the input pulse cycle (however, when the cycle is less than 1 s, measures the mean value of the input pulses)
	Trigger level adjustment function	A rotary dial at the right-hand side of the device is used to adjust the trigger level.

Output section	Analog output	Description of output function	Output with respect to the displayed rotation values	
		Output voltage	0 to 1 V/0 to FS (FS is freely selectable)	
		Conversion method	10-bit D/A conversion	
		Linearity	±1%/FS	
		Output update time	Within 50 ms + the time required for 1 cycle	
	Monitor output	Description of output function	Analog output for monitoring purposes after waveform reshaping of the sensor signal	
		Load resistance	At least 100 kΩ	
		Pulse output	Output voltage	Hi level: At least +4.5 V Lo level: Up to +0.5 V
			Output logic	Positive logic
			Load resistance	At least 100 kΩ
General specifications	Power source	Four AAA alkaline batteries or exclusive AC adapter (PB-7080, Option)		
	Battery life	At least 16 hours (when the backlight is OFF) At least 8 hours (when the backlight is ON)		
	Low battery alarm indicator	A low battery alarm (LOW mark) is displayed when the battery voltage falls below 4.4 V.		
	Operating temperature range	0 to 40°C		
	Storage temperature range	-10 to 50°C		
	Outer dimensions	189.5 (W) x 47.5 (H) x 66 (D) mm		
	Weight (including batteries)	Approx. 280 g		
Accessories	AAA alkaline batteries 4 Carrying case 1			

Options (sold separately)

For the SE-2500	Engine rotation detector VP-201 		For the SE-2500 and HT-6100	AC adapter PB-7080 	Signal cable (For both analog and pulse output signals) AX-501 
	Ignition detector IP-292 	Ignition detector IP-296 		Magnetic stand/Stand jig HT-0522/0521A 	Tripod LA-0203A 
For the HT-6100	Ignition detector IP-3000 	Electromagnetic detector OM-1200 	(shown with tachometer mounted)		

External diagrams

(Unit: mm)

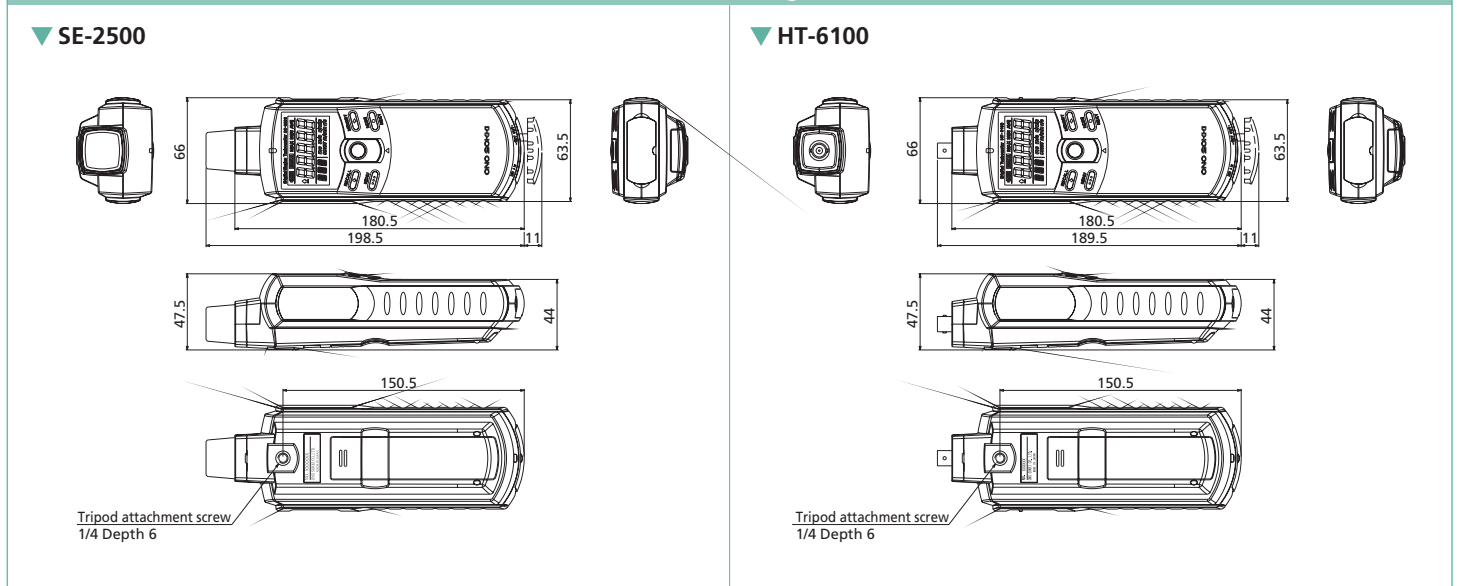

* Outer appearance and specifications are subject to change without prior notice.

URL : <http://www.onosokki.co.jp/English/english.htm>

ONO SOKKI

U.S.A. & CANADA
 Ono Sokki Technology Inc.
 2171 Executive Drive, Suite 400
 Addison, IL. 60101 U.S.A.
 Phone : 630-627-9700
 Fax : 630-627-0004
 URL : <http://www.onosokki.net>
 E-mail : info@onosokki.net

P.R.CHINA
 Ono Sokki Beijing Office
 Beijing Jing Guang Center 3510
 Hu Jia Lou, Chao Yang Qu
 Beijing P.R.C. 100020
 Phone : 010-6597-3113
 Fax : 010-6597-3114
 E-mail : onosokki@public.bta.net.ch

WORLDWIDE
 Ono Sokki Co., Ltd.
 1-16-1 Hakusan, Midori-ku,
 Yokohama 226-8507, Japan
 Phone : 045-935-3976
 Fax : 045-930-1906
 E-mail : overseas@onosokki.co.jp